

# SNOWDOGG<sup>®</sup> SNOW PLOWS

## INSTALLATION MANUAL

*for VMXII Plow Series with RapidLink<sup>™</sup>*



This manual is for the professional installation of SnowDogg® VMXII with RapidLink™ snow plows. Review all instructions prior to installation. Installation related failures are not covered by warranty.

## Table of Contents

1. Plow Registration/Warnings .....	2
2. Plow Assembly .....	2
- VMXII Moldboard/Lift Frame Assembly .....	3
3. Drop Foot Deployment .....	4
4. Light Bar Assembly .....	4
5. Vehicle Side Installation.....	5
- Vehicle Specific Mount Installation .....	5
6. Vehicle Side Electrical Installation.....	5
- Control Harness Installation.....	6
- Light Harness Installation.....	7
- Optional Accessory Wires.....	8
7. Plow Mounting and Checkout .....	9
8. Light Aiming.....	10
9. Storage/Maintenance .....	11
10. Warranty Information.....	12

## Plow Registration

Be sure to register your plow at [www.buyersproducts.com/support/productregistration](http://www.buyersproducts.com/support/productregistration) where you can also find installation instructions, technical specs, and full parts diagrams.

## Lift Frame and Moldboard Assemblies

LIFT FRAMES	MOLDBOARDS
VMXII – 16014100	VMX75II – 16022710

## Warnings

### WARNING

Read this manual carefully before operating this snowplow.

### WARNING

Always follow the vehicle manufacturers recommendations relating to snowplow installation.

### WARNING

When using on a vehicle with air bags, DO NOT tamper with, disable or remove any components related to the operation of the air bags.

### WARNING

When using on a vehicle with air bags, DO NOT tamper with, disable or remove any components related to the operation of the air bags. Vehicles equipped with air bags are designed such that the air bags will be activated in a frontal collision equivalent to hitting a solid barrier (such as a wall) at approximately 14 mph or more, or, roughly speaking, a frontal perpendicular collision with a parked car or truck of similar size at approximately 28 mph or more. Careless or high speed driving while plowing snow, which results in vehicle decelerations equivalent to or greater than the air bag deployment threshold described above, could deploy the air bag.

### WARNING

Make sure plow is properly attached and secured before moving vehicle.

### WARNING

Do not move plow while servicing or place any part of your body between or under plow parts while moving plow.

### WARNING

When transporting, position plow so as not to block driver line of sight or plow headlights.

### WARNING

DO NOT move the blade or exceed 50 MPH when transporting the plow.

### WARNING

DO NOT plow at speeds over 14 mph.

### WARNING

Always lower blade and power off controller when vehicle is not in use.

## Plow Assembly

SnowDogg® Plows are shipped almost fully assembled to reduce assembly time and simplify installation. The illustrations are representative and may vary from your actual hardware. Please refer to the tables for part numbers involved in installation. Full part diagrams can be found at [www.buyersproducts.com/usermanuals](http://www.buyersproducts.com/usermanuals)

**VMXII RapidLink™ Moldboard/Lift Frame Assembly**

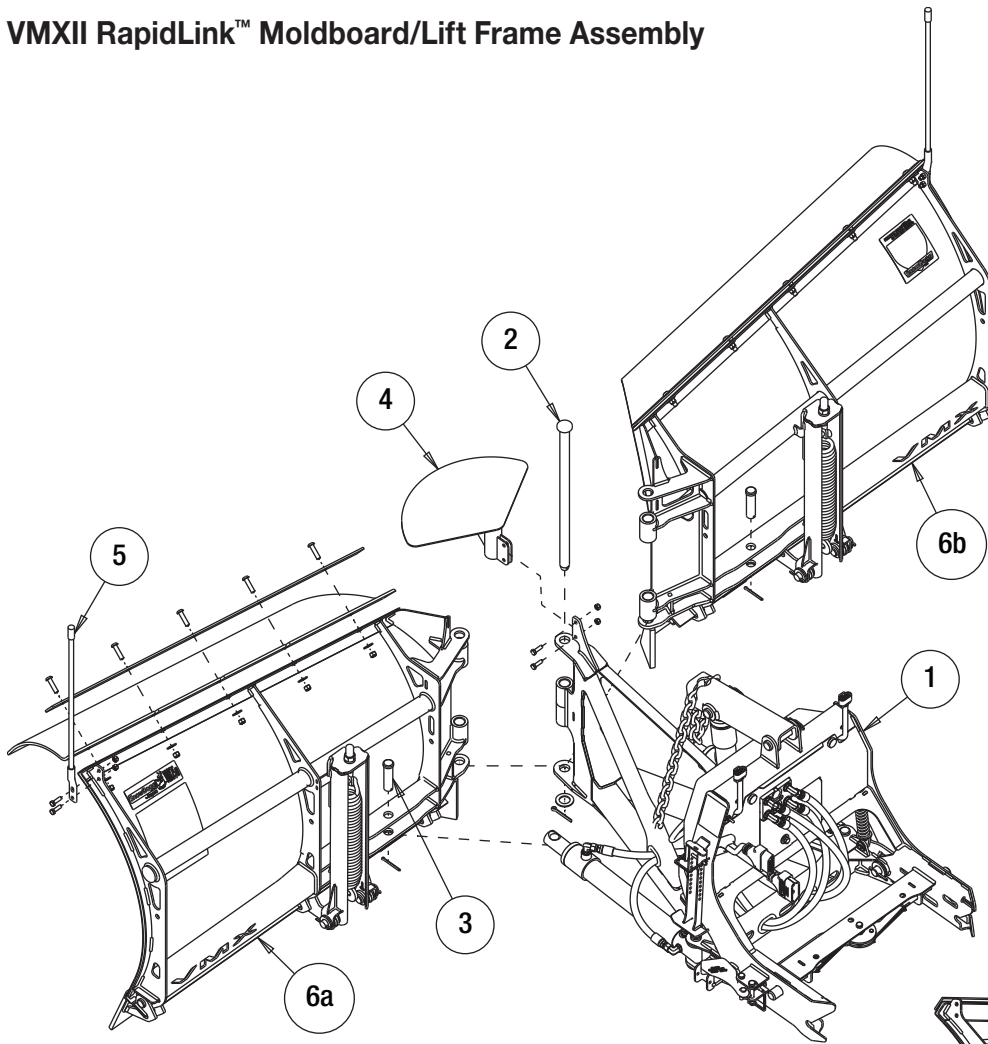

Fig. 1

**Bill of Materials**

ITEM	QTY.	PART NO.	DESCRIPTION
1	1	16014100	VMXII Lift Frame Assembly
2	1	16101170	VMXII Hinge Pin Kit
3	2	16102142	Clevis Pin Kit 7/8in x 3-1/4in
4	1	16113262	VMXII Center Deflector Cap
5	1	16122100	Blade Guide Kit (x2)
6	1	16022710	VMX75II Moldboard w/ Deflectors

**Assembly**

The moldboard wings can be propped on 4x4 blocks to get into position for mounting onto the a-frame. The lift frame can be slid forwards on the shipping pallet and a pallet jack can be used to adjust the height as needed.

**1.** Assemble the v-plow MOLDBOARD wings (6a and 6b) to the LIFT FRAME (1) as shown in Fig. 1 and Fig. 2 using the HINGE PIN KIT (2). Tap the hinge pin down, adjusting the wing positions as needed to allow for complete assembly.

**2.** Attach both angle cylinders on the LIFT FRAME to the MOLDBOARDS as shown using the 7/8in CLEVIS PIN KIT (3). The wings should move freely to allow attachment to the cylinder rods.

- 3.** Install the CENTER DEFLECTOR CAP (4) with hardware as shown.
- 4.** Install the snow deflectors by loosening the fasteners on the top strip of each MOLDBOARD wing. The deflector fits between the black retainer strip and the stainless MOLDBOARD. Only the OUTER TWO fasteners on each MOLDBOARD wing need to be completely removed.
- 5.** Install the BLADE GUIDES (5) as shown.
- 6.** Grease the six hinge pin tubes using a needle style grease gun tip. Do NOT install grease fittings in these holes as they will be damaged by normal plow movement.
- 7.** Before the plows first use, remove the fill plug on the reservoir and replace with the included relief plug.

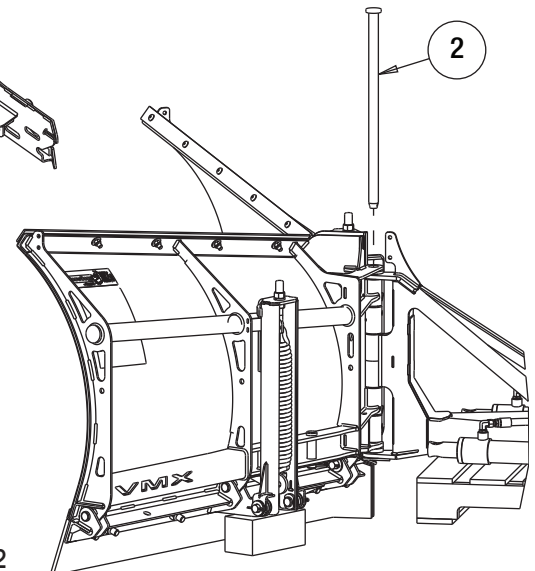

Fig. 2

## Drop Foot Deployment

1. Remove the snapper pin securing the drop foot to the lift frame and lift the drop foot off of the bracket.
2. Raise the rear of the a-frame approximately 6 inches from the floor.
3. Secure the drop foot to the a-frame bracket using the snapper pin. The drop foot should be positioned as close to the ground as possible for best support.

## Light Bar Assembly

1. Adjust the chain and rotate the lift frame upright for easier assembly of the light bar.
2. Remove the front and rear covers and set aside.
3. Rest the LIGHT BAR (2) on the LIFT FRAME (1) as shown in Fig. 4.
4. Loosely install the LIGHT BAR FASTENER KIT (3) as shown. After ensuring the light bar and lift frame are aligned, tighten fasteners.
5. Install the HALOGEN LIGHT KIT (4) or LED LIGHT KIT (4) using the included hardware. If the rubber shock spacers are included with the light kit hardware they should be installed under the spherical washers.
6. The plow light harness as shipped is routed through the holes on the back side of the lift frame. The side marked A is the DRIVER SIDE and the side marked B is the PASSENGER SIDE, correct if necessary.
7. Run the light harness wires up the inside of the light bar channels and through the openings at the top.
8. Inspect the lighting connectors to make sure the pins are straight and carefully connect the lights to the plow light harness. If the connectors are forced together, the pins may become bent.
9. Use the included zip ties to secure the light harness to the inside of the light bar.
10. Re-install the front and rear covers on the lift frame.

## Bill of Materials

ITEM	QTY.	PART NO.	DESCRIPTION
1	1	16014100	VMXII Lift Frame Assembly
2	1	16111644	VMXII Light Bar
3	1	16101022	VMXII Light Bar Fastener Kit
4	1	16160700A	Halogen Light Kit
	1	16160800	LED Light Kit

Make sure to adjust the chain so that there is enough slack to mount the plow. Not enough chain slack will prevent the lock pins from engaging during mounting.

**Your SnowDogg plow is now fully assembled and ready for mounting onto a properly configured vehicle.**

Fig. 3

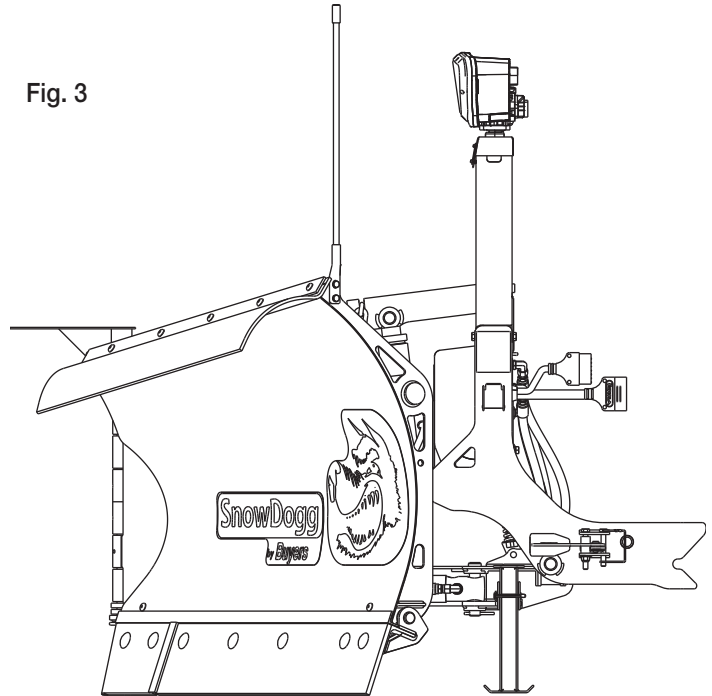
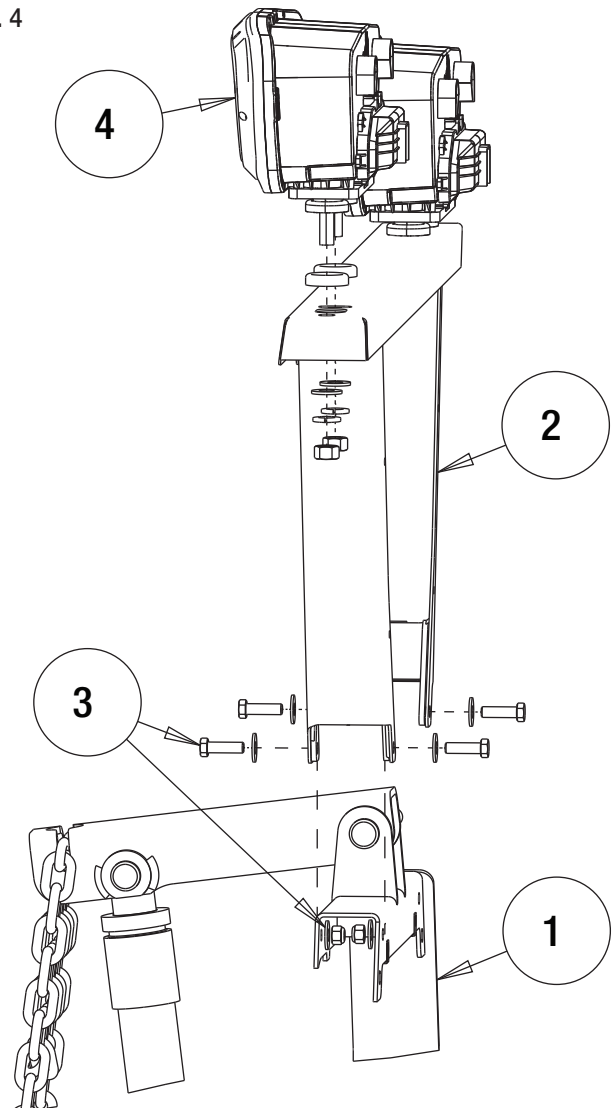

Fig. 4



## Vehicle Side Installation

Plowing is very hard on vehicles. For this reason any vehicle getting a plow mounted to it should be well maintained. Before installing a plow, and on a regular basis after, have the following systems checked and repaired as necessary:

- **Braking** - The additional weight and frequent starts/stops of plowing require your brakes to be working at their best.
- **Cooling** - Transporting the plow can block air flow to your radiator. Keep an eye on your temperature gage and make sure your cooling system is working as designed.
- **Suspension** - Plows really work out a front suspension even if you are within your FAWR limit. Have your suspension components checked regularly.
- **Transmission** - Snowplow operators probably drive in reverse more than any other driving professional. Keep your transmission well maintained, and ALWAYS fully stop before shifting from forward to reverse.
- **Lighting** - Plow lights require the truck lights to be working correctly. Any malfunction on the truck side will result in a malfunction on the plow side and make troubleshooting much more difficult. Always make sure your truck lights are working normally BEFORE you start an install.
- **Alignment** - The vehicle alignment should be checked and corrected AFTER the plow is installed.

## Vehicle Specific Mount Installation

Install the SnowDogg® Plow Mount required for your application following all instructions in the mount installation instructions(\*\*). Modification of your vehicles bumper/air dam/fascia may be required and will vary from vehicle to vehicle.

*\*\* VMXII with RapidLink plows use the same mounts used for the MD/MDII/VMD/VMDII series plows, however, due to changes in the lift geometry, the pushbar should be mounted with the solid round bar at ~10.50" — 11" from the ground.*

*For best performance, the A-frame should be parallel to the ground when the plow is mounted on the vehicle.*

### WARNING

Check all mounting hardware on a regular basis. Fasteners on plow mounts are subjected to a great deal of vibration and WILL loosen over time potentially causing the mount or plow to come loose from your vehicle.

## Vehicle Side Electrical Installation

The SnowDogg® plow has separate harnesses for the hydraulics and lighting for ease of installation and troubleshooting. Either harness can be omitted without affecting the functionality of the other system.

### CAUTION

Keep all connectors greased with dielectric grease on a regular basis to minimize corrosion & potential damage or wear to the pins. It is critical that all electrical connections be tight and secure. Loose connections on the plow circuit can cause overheating, component failure, or intermittent operation.



## Control Harness Installation

The truck side control harness is routed through the grill, by the battery, and through the firewall to the controller. It is preferable when possible to keep the plow connector on the driver side to make mount/dismount easier and faster. It is important that the 15A fused power lead go to an ignition switched source. Hooking direct to an "always on" source will cause a constant current draw and drain the vehicle battery. If an ignition switched source cannot be found, any switch rated at 15A can be used to turn off the power.

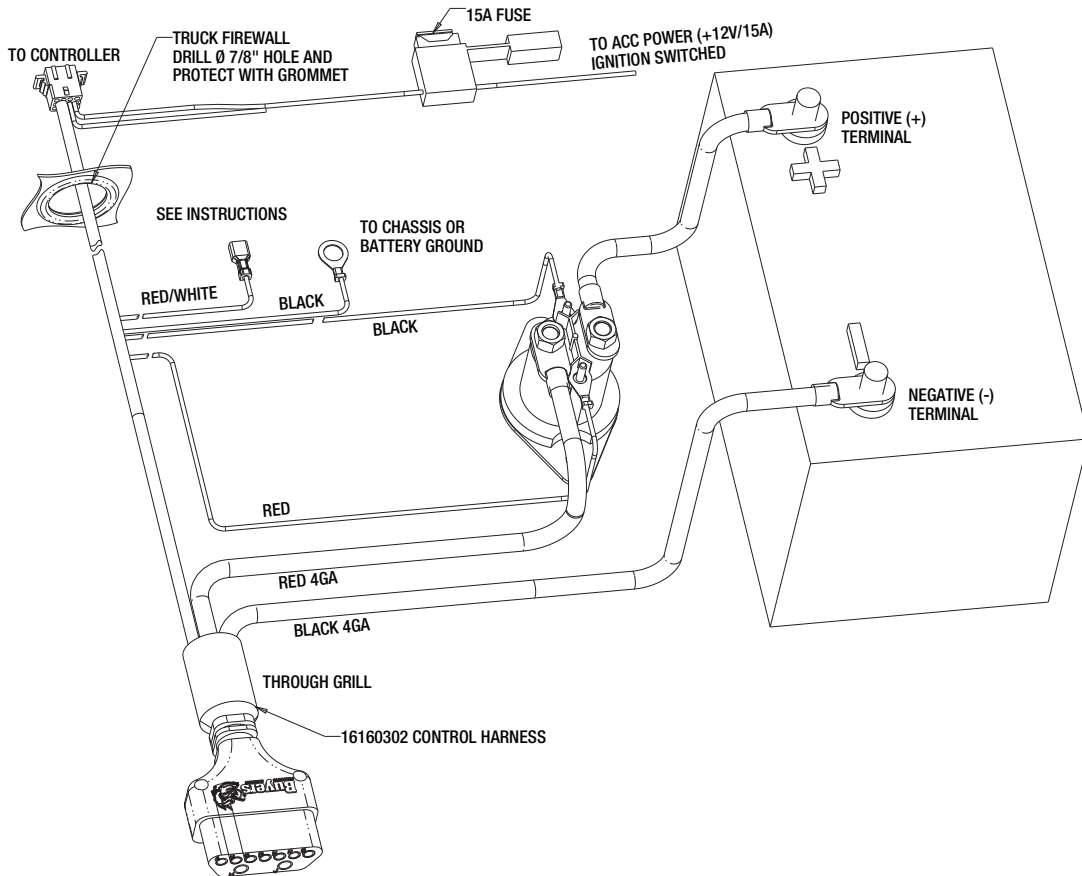

- 1.** Route the CONTROL HARNESS through the truck grill, by the battery, and through the firewall. If no available opening exists, a  $\varnothing 7/8$ " hole will need to be drilled through the firewall. Check your truck owner's manual for details on where this can be safely done. If the hole is drilled it is critical that a grommet be used to prevent damage to the wire harness.
- 2.** Mount the MOTOR RELAY in a convenient and secure location on the battery side of the vehicle using the included self tapping screws.
- 3.** The small RED and BLACK WIRES from the CONTROL HARNESS are connected to the small terminals of the MOTOR RELAY. It does not matter which wire goes to which terminal.
- 4.** The small BLACK WIRE with the eyelet should be connected to battery ground or a good chassis ground. A "dirty" ground will cause excessive power draw and can cause malfunctions in the lights and the controller.
- 5.** The RED/WHITE wire will be connected to the LIGHT HARNESS in the next step.
- 6.** The large (4 gage) BLACK WIRE on the CONTROL HARNESS must be connected directly to the NEGATIVE (-) battery terminal.
- 7.** The large (4 gage) RED WIRE on the CONTROL HARNESS is connected to one of the large terminals on the MOTOR RELAY. It does not matter which terminal is used.
- 8.** The shorter RED BATTERY CABLE is used to connect the other large terminal of the MOTOR RELAY with the POSITIVE (+) terminal on the battery.
- 9.** The CONTROLLER CONNECTOR is routed through the firewall.
- 10.** Connect the handheld controller and locate in a convenient location for the operator using the included mounting hardware if desired.
- 11.** The FUSED ACC POWER WIRE coming off of the controller connector must be connected to an IGNITION SWITCHED 15A/12V power source. Hooking direct to an "always on" source will cause a constant current draw and drain the vehicle battery. If an ignition switched source cannot be found, any switch rated at 15A can be used to turn off the power.

## Light Harness Installation

The light harness is split into a RELAY MODULE and GRILL HARNESS to allow for easy installation. Connectors have been designed in such a way to prevent installation errors – but be sure to read all instructions.

1. Install the appropriate 1607XXXX headlight adapter (and accessories) using the instructions.
2. Route the GRILL HARNESS through the grill (drivers side preferably).
3. Locate the RELAY MODULE close to either the driver or passenger side headlight (whichever is convenient) and connect the 8-pin connector to the GRILL HARNESS.
4. Route and connect your 1607XXXX headlight adapters to the RELAY MODULE.
5. Connect the BLACK wire with ring terminal to the battery or a clean chassis ground. If a chassis ground is used, it would be best to use the same location used for the CONTROL HARNESS.
6. Connect the purple TURN SIGNAL wires between the harnesses.
  - a. If your “A” headlight adapter is on the DRIVER SIDE
    - i. Connect PURPLE/WHITE to PURPLE/WHITE
    - ii. Connect PURPLE/BLACK to PURPLE/BLACK
  - b. If your “B” headlight adapter is on the DRIVER SIDE
    - i. Connect PURPLE/WHITE to PURPLE/BLACK
    - ii. Connect PURPLE/BLACK to PURPLE/WHITE
  - c. If you find that your plow turn signals are backwards from the truck – swap the wires.
7. The final configuration steps require you to know if your vehicle is STANDARD or SWITCHED GROUND installation. MOST vehicles are STANDARD. ALWAYS verify your application on the application guide before configuring. Configuring your harness incorrectly can result in blown fuses and troubleshooting hassles.

## Standard Installation

- Connect the ORANGE wire on the RELAY MODULE to the RED/WHITE wire on the CONTROL HARNESS. This supplies ignition switched power to the light relays.

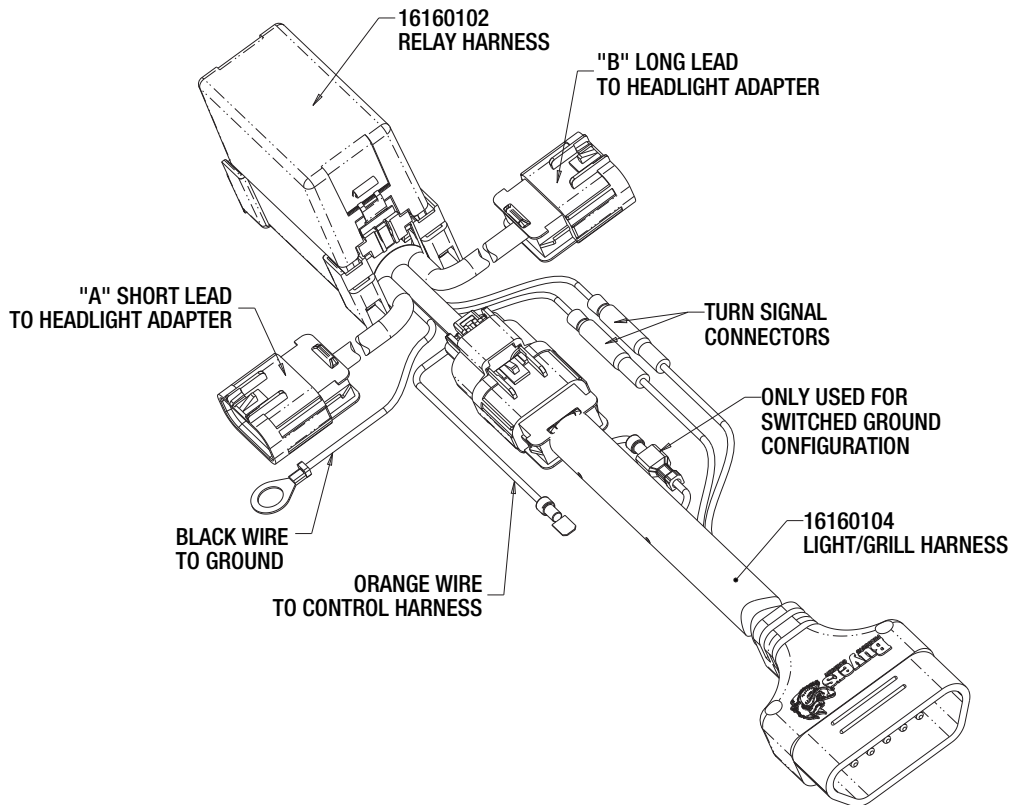

## Switched Ground

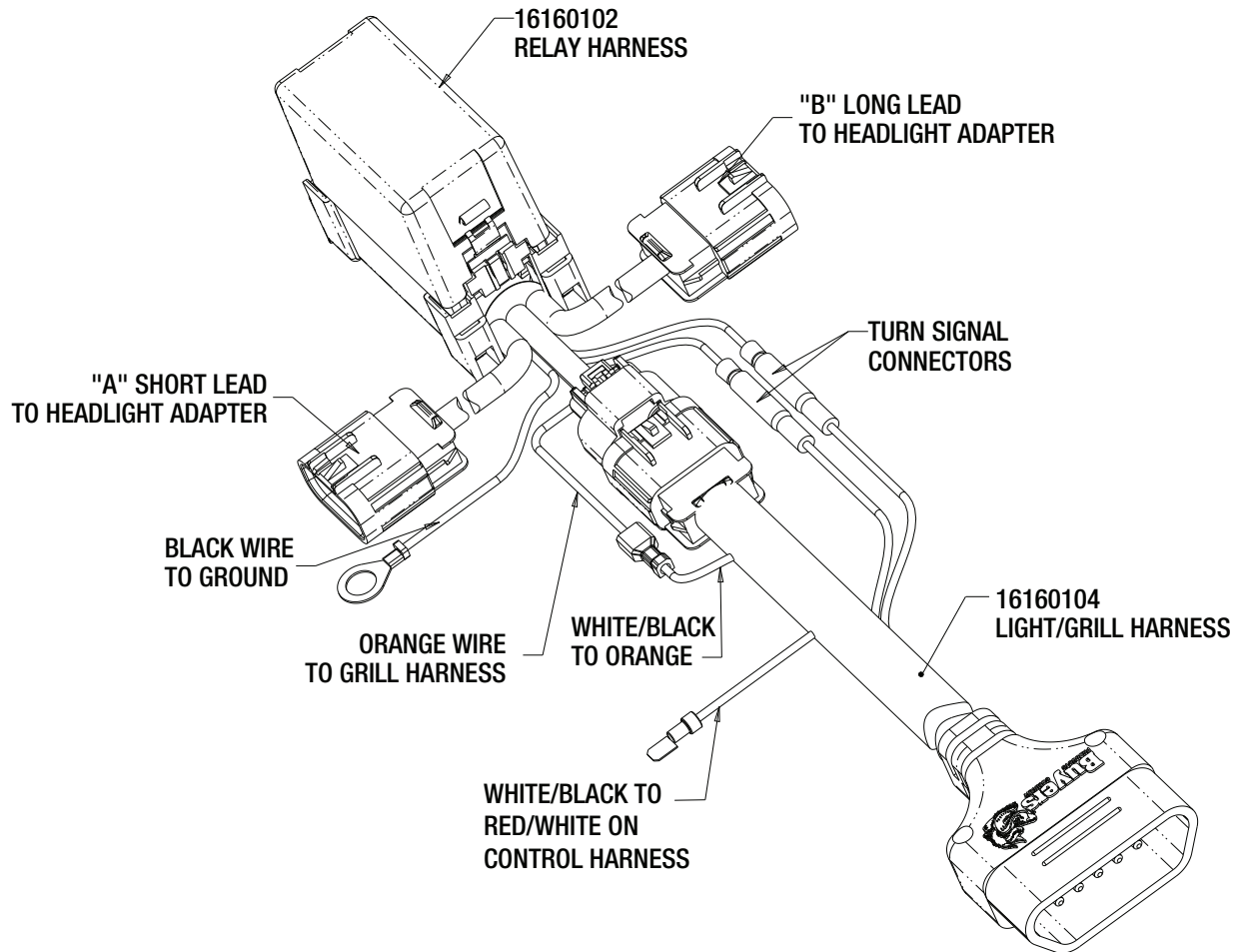

- Cut open the loom on the GRILL HARNESS near the 8-pin connector to locate the WHITE/BLACK wire. This wire has male and female connectors in line.
- Disconnect the WHITE/BLACK wires (male and female connectors) from each other on the GRILL HARNESS.
- Connect the ORANGE wire on the RELAY MODULE to the WHITE/BLACK wire on the GRILL HARNESS (the wire that goes back to the relay box). This supplies ground to the relay coils when the plow is connected.
- Connect the WHITE/BLACK wire on the GRILL HARNESS (the wire that goes toward the grill) to the RED/WHITE wire on the CONTROL HARNESS. This supplies ignition switched power to the common wire of the plow lights.

**8.** With the plow disconnected, check all light functions on the vehicle.

**9.** Connect the plow and check all light functions on the plow.

### Optional Accessory Wires

There are two extra blunt cut wires (RED and BLUE) in the GRILL HARNESS near the 8-pin connector. These wires are for optional accessories mounted on the plow. They end at the 5-pin light connectors on the plow – and go to both the driver and passenger side light connectors. If these are used, they should be properly terminated. These wires are suitable for 15A of current.



## Plow Mounting And Checkout

Your fully assembled plow is now ready to mount to the vehicle that you have prepared. Mount the plow using the instructions as shown.

### MOUNTED PLOW

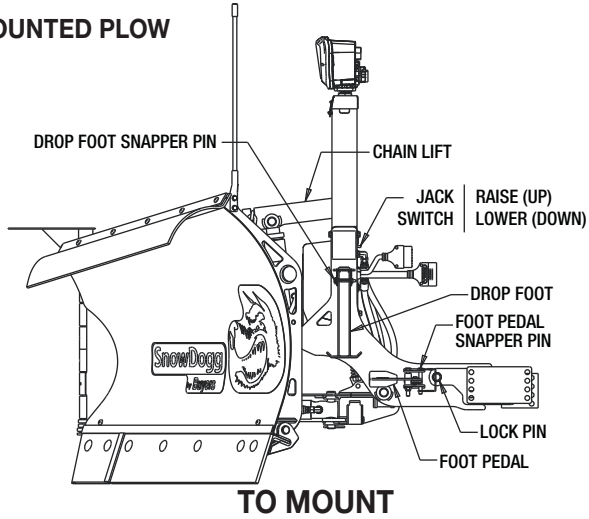

1. Check that the LOCK PINS are fully retracted. If not, push the FOOT PEDAL towards the truck to lock the pins in the retracted position.
2. Drive into the plow so that the PUSHBAR makes full contact on both sides.
3. Get out of the truck and check if the PUSHBAR is properly aligned with the RECEIVER NOTCH (see diagram 1). If not properly aligned, see "Using the Jack Switch" section below.
4. Pull the FOOT PEDAL away from the truck to release the LOCK PINS.
5. Push the center of the light tower towards the truck to mount the plow. The LOCK PINS should extend through the PUSHBAR EARS and be visible on both sides.
6. Insert the FOOT PEDAL SNAPPER PIN to prevent unintended movement of the FOOT PEDAL. If the FOOT PEDAL SNAPPER PIN cannot be inserted, check that the LOCK PINS are fully extended and visible on both sides. If this is not happening, re-check alignment (see diagram 1).
7. Remove the DROP FOOT from the a-frame and stow it on the lift frame bracket using the DROP FOOT SNAPPER PIN.
8. Connect the lighting and hydraulic connectors if not already connected.

### USING THE JACK SWITCH

*If the RECEIVER NOTCH is too low to allow for proper alignment with the PUSHBAR, the JACK SWITCH can be used to raise the plow receiver.*

1. Position the truck 6"-12" from the plow to allow room to raise the plow receiver.
2. Enter MOUNT mode: turn the plow controller on and hold DOWN for 1 second. Repeat: hold DOWN again for 1 second. The status indicator will blink red rapidly.
3. Connect the lighting and hydraulic connectors.
4. Push the JACK SWITCH up to raise the rear of the lift frame. If the lift frame ends up sitting too high, push the JACK SWITCH down to lower the rear of the lift frame. Adjust the lift frame so that the RECEIVER NOTCH is at the same height as the PUSHBAR.
5. Drive into the plow so that the PUSHBAR makes full contact on both sides and then make a final alignment check.
6. Push the JACK SWITCH down and then press down on the CHAIN LIFT until the lift cylinder is fully retracted. The chain MUST have slack to mount the plow.

### DISMOUNTED PLOW

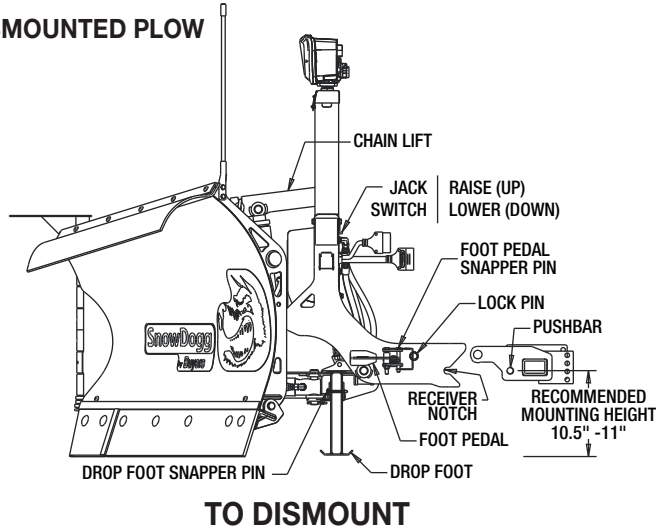

1. Enter FLOAT mode: turn the plow controller on and hold the DOWN button for 1 second. The status indicator will turn blue.
2. Press down on the CHAIN LIFT to ensure the lift cylinder is fully retracted. The chain MUST have slack to dismount plow.
3. Remove the DROP FOOT from the lift frame and secure it to the a-frame bracket using the DROP FOOT SNAPPER PIN. The DROP FOOT should be positioned as close to the ground as possible for best support.
4. Remove the FOOT PEDAL SNAPPER PIN and push the FOOT PEDAL towards the truck to disarm the LOCK PINS.
5. Push the center of the light tower towards the truck until both LOCK PINS retract.
6. Disconnect the lighting and hydraulic connectors.
7. Back away from the plow.

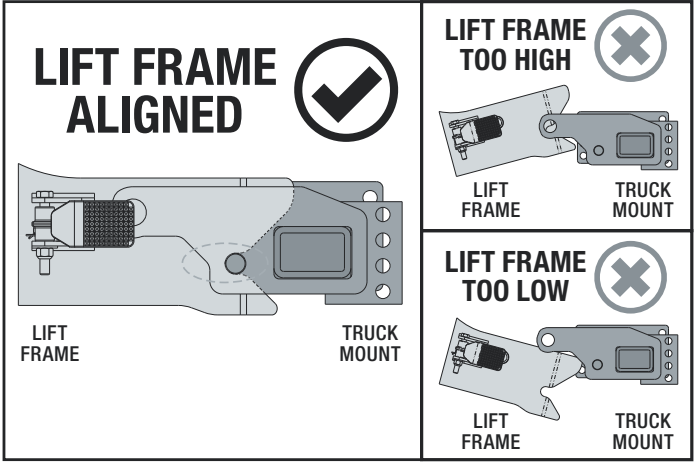

Diagram 1

Power on the plow controller and operate the plow through all functions

**CAUTION**

For safety reasons, the blade drops very slowly on the plow as shipped. To increase the drop speed of the blade, use a flat blade screwdriver to turn the lowering speed adjustment on the front of the hydraulic power unit counter clockwise. Turn it clockwise to slow the blade drop speed. Do this only while the blade is lowered, and tighten the jam nut after adjusting

Verify that all plow lights work properly

- LOW BEAM
- HIGH BEAM
- FLASH TO PASS
- TURN SIGNALS
- PARKING LIGHTS

Mount and Dismount the plow several times to confirm that all components work as intended. If any portion of the truck bumper or air dam interferes with mounting, it may need to be removed or the pushbar lowered. With the floating a-frame, the pushbar mounting height can vary significantly without impacting plow performance.

**Light Aiming**

1. Place the vehicle on a level surface 25 feet in front of a matte-white screen, such as a white wall or garage door.
2. The snowplow should be mounted, with the blade raised in transport position.
3. Check that the truck is in normal operating condition with no flat tires, failed suspension components, and no passengers.
4. Mark the horizontal centerline of the vehicle headlights on the screen (a line matching the height of the headlights from the ground). Mark the vertical centerline of the vehicle headlights on the screen (lines matching the headlight center to center distance).
5. The high intensity zone of the low beams should be just below the horizontal line and the right of the vertical lines (see diagram below). Adjust the headlight aim as required.

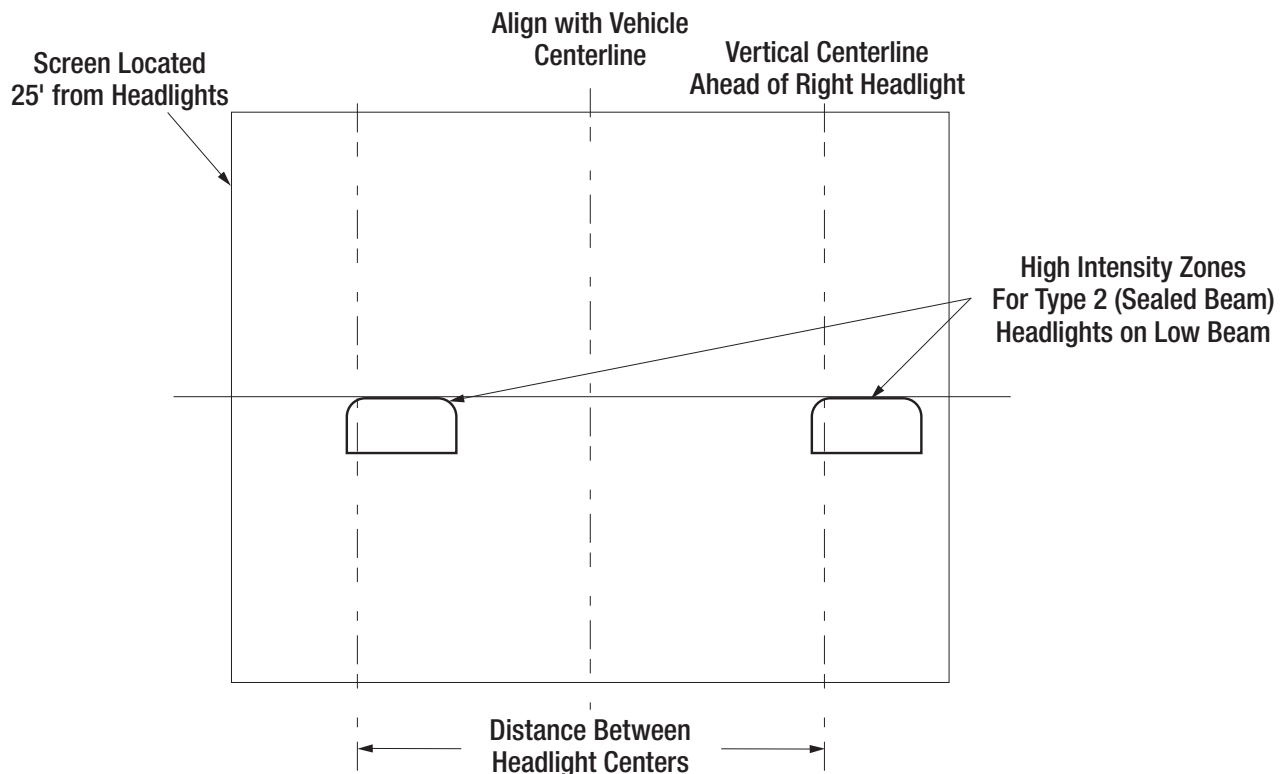



**NOTE: Snowplow installers must certify that installation conforms to federal motor vehicle safety standards.**

Your plow and truck are now ready for operation. The hydraulic system has been filled at the factory and should be fully operational. It is possible that agitation due to shipping has introduced some air into the oil. When operating the plow for the first time some oil may exit the vent (by the coils). This should stop once the plow is cycled and operational. *Check all plow and light functions. If something is not working correctly, reread the installation directions to make sure a step was not missed and check the schematics.*

## **Storage**

1. Before disconnecting the plow from your vehicle, fully compress the lift cylinder.
2. Disconnect the plow from your vehicle.
3. Coat all electrical connection points with dielectric grease.
4. Repair/touch up any chipped paint or rusted areas.
5. Apply a coat of oil or grease to all exposed chrome (on angle and lift cylinders).
6. Grease all grease fittings on trip pins and king pin.

## **Removal From Storage**

1. Check all fasteners and hydraulic fittings for tightness.
2. Replace any cracked hydraulic hoses.
3. Coat all electrical connection points with dielectric grease.
4. Connect the plow to the vehicle.

## **Maintenance**

The SnowDogg® line of plows have been simply designed for reliable service. In order to ensure the reliability of your plow, observe the following maintenance items and regularly inspect:

- Fasteners and retaining devices for proper installation and tightness
- Hydraulic cylinders for damage, pitting or leakage
- Hydraulic hoses for wear, damage or leakage - replace as required
- All electrical connections for corrosion – apply dielectric grease as required
- Cutting edge wear
- Plow shoe wear
- Greasable fittings

## **Hydraulic System**

- All SnowDogg® plows use SnowDogg® brand Low-Temperature Hydraulic Fluid (P/N 16150010) available from SnowDogg® dealers.
- The reservoir should be filled through the top port until oil reaches the top port.
- Recheck and tighten all fittings and valves every season or as necessary. Vibration due to normal use can cause fittings to loosen.
- Loctite or Teflon tape should not be used on any fittings or hoses. The only plugs where pipe sealant may be used are the reservoir plugs.
- The reservoir should be drained and refilled every season to ensure that the oil remains free of water and contaminants. If contaminants are known to be present, it is recommended that the reservoir be removed and cleaned.

**With proper maintenance and care your SnowDogg® plow will provide years of trouble free service!**

# Limited Warranty

.....

## **COVERAGE**

Buyers Products Company warrants to the original purchaser of a Buyers Products SnowDogg® brand snowplow that they will be free from defects in materials and workmanship for a period of two (2) years after the date of original purchase. Buyers Products warrants accessories, service parts, and components purchased separately to be free of defects in materials and workmanship for a period of one (1) year after date of original purchase.

These warranties are exclusive and in lieu of all other express and, except to the extent prohibited by applicable law, all implied warranties, including but not limited to the implied warranties of merchantability and fitness for a particular purpose, are limited in duration to the duration of this warranty.

Buyers Product's Liability is expressly limited to repair or replacement of defective parts. Buyers Products shall not be liable for consequential, incidental or contingent damages whatsoever, even if damages are caused by the negligence or fault of Buyers Products.

This warranty gives you specific legal rights. Additional purchaser's rights may vary from state to state.

## **WHAT IS NOT COVERED**

The warranty does not apply to:

- ...parts not furnished by Buyers Products or damage resulting from same.
- ...parts modified without authorization or damage resulting from same.
- ...expendable parts (cutting edges, fluids, etc.).
- ...damage resulting from failure to install, maintain or operate the product per the owner's manual, installation instructions, or application guides.
- ...damage to vehicle and/or frame of vehicle resulting from plow attachment.

## **WARRANTY PROCEDURE**

**If any part is proven to be defective within that warranty period, Buyers Products will, at its sole discretion, repair or replace said part at its expense FOB Cleveland, OH. Labor will be credited to authorized dealers as determined by published rate charts.**

Buyers Products obligation shall be limited to such repair or replacement and shall be further contingent on Buyers Products receiving written notice of the alleged defect and proof of original purchase within ten (10) days of its discovery as well as the return of the allegedly defective part to Buyers Products.

To obtain service, the purchaser must return the defective snowplow to an authorized SnowDogg® Dealer with proof of purchase and applicable maintenance records. All transportation costs to and from the dealer will be the responsibility of the purchaser.

SnowDogg® dealers may be located on-line at [www.buyersproducts.com/dealerlocator](http://www.buyersproducts.com/dealerlocator).

Buyers Products  
9049 Tyler Blvd.  
Mentor, OH 44060

**Contact Your Dealer for Service and Technical Support**